

2023 WPLF WINTER TRAINING CONFERENCE & EXPO

FEBRUARY 5TH - 8TH

KALAHARI RESORT & CONVENTION CENTER | WISCONSIN DELLS, WI



PROUDLY SPONSORED IN PART BY:





2023 WPLF WINTER TRAINING CONFERENCE



EVENT SPONSORS

SPECIAL THANKS TO OUR CONFERENCE SPONSORS

LUNCH SPONSORS



WCPA/WPLF BOARD MEETING SPONSOR

PRESIDENT'S DINNER & RECEPTION SPONSOR



PAST PRESIDENT'S RECEPTION SPONSOR

GENERAL SPONSOR



FBINAA BREAKFAST SPONSOR

PRAYER BREAKFAST SPONSOR



BREAK SPONSORS



SAVE TIME. SAVE LIVES.



2023 WPLF WINTER TRAINING CONFERENCE



EVENT SPONSORS

HOST CHIEF'S NIGHT SPONSORS



TABLE OF CONTENTS|

Conference Event Sponsors.....	1
Welcome Message.....	3
Sunday Schedule of Events.....	6
Madison Area Addiction Recovery Initiative.....	7
Monday Schedule of Events.....	10
Hiring & Retention Strategies: It's Your Job.....	11
Transformational Leadership.....	13
Host Chief's Night.....	15
Prayer Breakfast.....	17
Exhibitor Passport Program.....	19
Tuesday Schedule of Events.....	20
Wisconsin Act 75 - Duty to Intervene & Off-Duty Considerations.....	21
Waukesha Christmas Parade Case Study.....	23
Leadership for a Lifetime: How the Past Prepares Us for the Future.....	25
President's Reception & Dinner Banquet.....	26
Wednesday Schedule of Events.....	28
Wisconsin Attorney General and Miscellaneous Legal Updates.....	29
Wisconsin's New High-Risk Vehicle Contract Model & WI DOJ T&S Bureau Updates.....	31
Midwest Organized Crime Information Center (MOCIC) & WI LEDR Updates.....	33
Federal Civil Rights.....	35
Exhibition Hall Floor Plan & Hours.....	37
Alphabetical Exhibitor List.....	39
Door Prize Donation List.....	41
WCPA Partnership Programs.....	43
Supporting Business Members.....	47
WCPA Membership Challenge Program.....	49
2023 WPLF Summer Conference Save the Date.....	54

ADVERTISERS|

3M.....	4
DATAMARK.....	5
TC Networks.....	6
5.11 Tactical.....	8
Axon.....	9
Lexipol.....	12
Anew Advisors.....	14
Baycom.....	16
Police & Sheriff's Press.....	18
Verizon.....	19
Virtual Academy.....	22
Community Security Solutions, LLC.....	24
Panasonic.....	27
Chorus Intelligence.....	30
Harley-Davidson.....	32
LexisNexis CopLogic Solutions.....	34
RTAI Printers.....	36
Flock Safety.....	38
CTech Manufacturing.....	42
Critical Response Group.....	44
GenComm.....	46
Ray O'Herron Co.....	50
Wisconsin Surplus Online Auction.....	51
Gamber Johnson.....	52
UScellular.....	53
IAG Wealth Partners (Jason Ganiere).....	54
WReeves & Associates.....	-



2023 WPLF WINTER TRAINING CONFERENCE



WELCOME ADDRESS

WPLF TRAINING COMMITTEE MEMBERS

- Timothy Strohbusch (Chair)**
Clear Lake Police Department
- Lloyd Gauthier**
Rhineland Police Department
- Sean Marschke**
Sturtevant Police Department
- Torin Misko**
Harland Police Department
- Aaron Olson**
Neenah Police Department
- James Olson**
DeForest Police Department
- Ryan Rosenow**
Greendale Police Department
- Michael Snow**
Germantown Police Department
- Steven Roux**
Rice Lake Police Department
- Kyle Teynor**
Prairie du Chien Department
- Justin Tim**
Williams Bay Police Department

WCPA Members, Conference Attendees and Exhibitors -

Welcome to Wisconsin Dells!

Wisconsin Dells has become the home of our Winter Conference and Expo, and what a home it is. The recreational opportunities in and around the Kalahari Resort are seemingly endless and our conference and expo facilities continue to support our needs and amazing growth.

Your Boards of Directors work tirelessly to assure the future of law enforcement leadership has access to resources and strategies found nowhere else. Our conferences also create opportunities for developing valuable relationships.

Your Training Committee (a function of the WPLF) works throughout the year to bring you contemporary and beneficial educational sessions to improve your skills and those of your team. Once again, they have done a great job of vetting potential speakers and topics. This year's presentations of current law enforcement leadership topics will be thought provoking and informative.

Kudos to our Training Committee for a job well done. Our Committee members are listed on the left column. Please take a minute to show your appreciation when you see them at our conference, but more importantly, if you have a speaker or topic you would like to see at a future conference, please contact a Committee member.

We also hope the WPLF Winter Conference allows you a chance to put the office behind you and recharge your batteries. Our "Host Chief's Night" in our exhibition hall is a great place to develop relationships with participants and exhibitors, while our annual President's Banquet will allow recognition of Wisconsin WILEAG agencies and individuals as well as our new WCPA President's acceptance address.

A special thanks to our volunteers, most of whom are retired members of the WCPA. Likewise, we would be remiss if we didn't mention the assistance of our local law enforcement agencies who provide security at our event as well as the local Sauk County Triad whose personnel assist with registration. Your commitment to this conference is greatly appreciated.

Sincerely,



Chief Patrick Mitchell
West Allis Police Department
WPLF President



Chief Steven Roux
Rice Lake Police Department
WCPA President

3M Science.
Applied to Life.™



3M Traffic Safety and Security

Twice as bright, day or night.

Easier for law enforcement to read at greater distances

3M™ High Definition License Plate Sheeting

Time never slows down, even when vehicles should. While you're working to keep roadways regulated and safe, drivers need license plates that convey instant clarity and visibility. High Definition License Plate Sheeting Series 6700 uses micro-replicated optical elements to improve license plate visibility and legibility day or night, rain or shine.

Make the move to high definition at [3M.com/VehicleRegistration](https://www.3m.com/VehicleRegistration)

© 3M 2019. All rights reserved.

When Every Second Counts, Count on Us.



**PUBLIC SAFETY
GIS SOLUTIONS**



**OPERATIONALIZE
INDOOR MAPPING**



**GIS DATA
HOSTING**



SCHEDULE OF EVENTS

SUNDAY, FEBRUARY 5TH



Start Time	End Time	Description	Location
10:00 AM	2:00 PM	WCPA/WPLF Joint Board Meeting (includes working lunch) <i>Sponsored by: DATAMARK</i>	Africa Breakout Room 50
10:00 AM	6:00 PM	Attendee Conference Registration	Registration Africa West
12:00 PM	6:00 PM	Early Exhibitor Registration & Booth Set-Up	Registration Africa East
1:00 PM	5:00 PM	Wisconsin Police Executive Group (WIPEG) Meeting	Africa Breakout Room 60
3:00 PM	4:00 PM	WCPA Nominating Committee Meeting	Africa Breakout Room 80
4:00 PM	5:00 PM	Past-Presidents Meeting/Reception <i>Sponsored by: 3M</i>	
3:00 PM	4:00 PM	4th Class Cities, Villages & Towns Committee Meeting	Africa Breakout Room 70
3:00 PM	4:30 PM	WCPA Training Committee Meeting	Ebony Room
5:30 PM	7:00 PM	"Madison Area Addiction Recovery Initiative" Presented by Captain Matt Tye & Commander (ret.) Joe Balles (Madison Police Dept.)	Rooms A,B,G & H

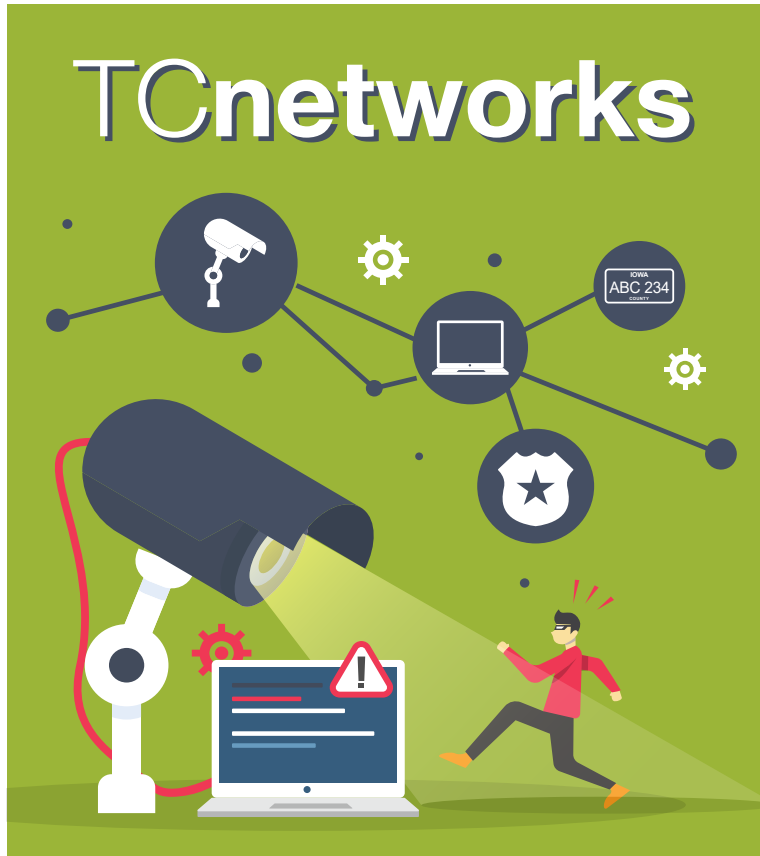

**SECURITY CAMERAS
ACCESS CONTROL
LICENSE PLATE RECOGNITION
MOBILE CAMERAS**

EXPERIENCE

TC Networks has worked with municipalities of all sizes to build comprehensive, scalable, city-wide camera networks.

RESOURCES

Knowing how limited and restrictive local government budgets are, starting the conversation is the first step in implementing a camera network whether it is a short-term or long-term goal.

NO CHARGE CONSULTATION

TC Networks would appreciate an opportunity to set up an on-site visit with your team. Working with you and your team, we can determine the best way to capture incidents of all types.

Please stop by the **TC NETWORKS BOOTH #209** for a **FREE GIFT** and demonstration on how security cameras and specifically license plate recognition can benefit your community.



CONFERENCE SPEAKERS & PRESENTATIONS



MADISON AREA ADDICTION RECOVERY INITIATIVE



Captain (ret.) Joe Balles
Madison Police Dept. (WI)

In September of 2020, the Madison Police Department (MPD) launched the Madison Recovery Initiative (MARI), a three-year pilot program funded by a \$700,000 Smart policing grant provided by the U.S. Department of Justice (USDOJ) to help fight against the opioid epidemic. Under the program, MPD officers can provide many opioid abusers with the opportunity for treatment, rather than arrest. If treatment is chosen, the individual is connected with a professional intake counselor who screens and provides them with assistance in getting into residential or outpatient treatment programs. Additionally, those participating in the program are provided with access to peer support recovery coaches that provide comfort and encouragement them engage treatment. The program also supports self-referrals, meaning individuals can contact the MPD directly – without risk of arrest – and be referred to the program. This presentation is being provided by Captain (ret.) Joe Balles and the Captain Matt Tye of the MPD, key stakeholders in the initiative who will provide insight relating to various aspects of the program including its planning, funding, implementation and effectiveness.

Captain Joe Balles retired from the MPD in January 2016 after a distinguished 32-year career. In March 2017, at the request of the MPD, Captain Balles returned to the agency to serve the MAARI program's project coordinator. Captain Balles coordinated this initial grant project for MPD through April 2021, and recently co-authored a series of articles for academic journals with staff from the Penn State Medical School detailing the implementation and evaluation of MARI. After the initial grant, the MPD was awarded a follow-up grant from the USDOJ to continue and expand the program, now referred to as the Madison Area Addiction Recovery Initiative (MAARI), to other agencies as well as to increase community outreach efforts to those battling the disease of addiction by offering additional pathways to recovery. Today, Captain Balles is helping to coordinate the follow-up grant which is now entering its final year of funding.



Captain Matt Tye
Madison Police Dept. (WI)

Captain Matt Tye has been with the MPD for over 22 years. He holds a Bachelor of Arts Degree from Northwestern University and a Law Degree from the University of Wisconsin. He is currently the Captain of Community Outreach overseeing the MPD's Mental Health Unit, the Addiction Resource Team, as well as all department outreach engagements and restorative justice initiatives. Captain Tye has also worked with the Madison Metropolitan School District overseeing the STOP School Violence grant and the establishment and training of threat assessment and critical response teams within the school district. Moreover, he is the Deputy Commander of the Special Events Team responsible for crowd management within the City of Madison. Captain Tye is interested in improving the use of data analysis and evidenced based practices in the areas of criminal diversion and community engagement.

Prior to his current assignments, Captain Tye served as a Patrol Lieutenant, a Detective Lieutenant, Detective and Police Officer. In these roles, he served as supervisor to many units with the MPD including the Special Victims Unit, SWAT and Crisis Negotiation Team.

5.11 FIT FOR DUTY

On or off duty, we have the gear that will keep you ready far beyond your shift.



WEAR TEST REQUEST





**SAFER, MORE EFFICIENT POLICING
WITH A CONNECTED ECOSYSTEM
OF PUBLIC SAFETY TECHNOLOGY**

Safety & Certainty with Axon Technology



 **+1 800-978-2737**

www.axon.com



SCHEDULE OF EVENTS

MONDAY, FEBRUARY 6TH



Start Time	End Time	Description	Location
7:00 AM	8:00 AM	Complimentary Continental Breakfast	Exhibition Hall
7:00 AM	5:00 PM	Attendee Conference Registration	Registration Africa West
7:00 AM	9:00 AM	Exhibitor Registration & Booth Set-Up	Registration Africa East
8:00 AM	8:15 AM	Opening Ceremony <i>with Welcome Message by WCPA President</i>	Rooms A, B, G & H
8:15 AM	8:30 AM	"Annual Membership Meeting" <i>for the purpose of initiating elections for 3rd vice-president.</i> NOTE: Election ballots will be distributed and collected immediately thereafter.	
8:30 AM	9:45 AM	"Hiring & Retention Strategies: It's Your Job" <i>Presented by Mr. Gordon Graham (Co-founder of Lexipol)</i>	Rooms A, B, G & H
9:30 AM	7:30 PM	Exhibition Hall/Booth Displays Open	Exhibition Hall
9:45 AM	10:30 AM	Break with Exhibitors <i>Sponsored by: Community Security Solutions, Motorola Solutions and Safe Haven Defense</i>	
10:30 AM	12:00 PM	"Hiring & Retention Strategies: It's Your Job" <i>(continued)</i>	Rooms A, B, G & H
12:00 PM	1:00 PM	Lunch with Exhibitors <i>Sponsored by: 5.11 Tactical and Axon</i>	Exhibition Hall
1:00 PM	2:30 PM	"Transformational Leadership" <i>Presented by Chief Dave Funkhouser (Kiel Police Dept.)</i>	Rooms A, B, G & H
2:30 PM	3:15 PM	Break with Exhibitors <i>Sponsored by: Bradford Systems, PowerDMS and ZeroEyes</i>	Exhibition Hall
3:15 PM	5:00 PM	"Transformational Leadership" <i>(continued)</i>	Rooms A, B, G & H
5:30 PM	7:30 PM	Host Chief's Night <i>Sponsored by: Anew Advisors, Baycom, Panasonic, Charter Communications, Chorus Intelligence, Critical Response Group, CTech Manufacturing, Flock Safety, Gamber Johnson, GenComm, UScellular Harley-Davidson, Ray O'Herron Co. and WReeves & Associates</i>	Exhibition Hall



CONFERENCE SPEAKERS & PRESENTATIONS



HIRING AND RETENTION STRATEGIES: IT'S YOUR JOB



Mr. Gordon Graham
Co-founder of Lexipol



How do we get and keep good people in law enforcement? And what does risk management have to do with hiring and retention? It's integral to your operations - and it's everyone's job.

On February 6, 2023, join international risk management expert and co-founder of Lexipol, Gordon Graham, to learn how you, your personnel, and everyone in your organization can get and keep excellent people in law enforcement. Over the course of almost three hours, Gordon will provide a framework for attentive listeners to put into practice when they get back to work. This framework includes, but is not limited to, recruitment efforts, career development efforts, comprehensive background investigations, performance evaluations, and how to properly use policy and training to enhance organizational excellence. Don't miss your chance to spend time with Gordon Graham!

Mr. Gordon Graham is a 33-year veteran (now retired) of California law enforcement. In this capacity, he served as a street cop, supervisor, manager, and executive. Mr. Graham was awarded a B.A. in Business from San Francisco State College, a teaching credential from California State University, Long Beach, a master's degree in Safety and Systems Management from the University of Southern California, and a juris doctorate from Western State University. He has taken his background as a cop, risk manager and attorney and is the co-founder of Lexipol, a company designed to standardize public safety practices around America. He has presented to law enforcement personnel from around the world.



MISSION CRITICAL SOLUTIONS



Policies



Wellness



Online Learning



Grant Services

info.lexipol.com/wcpa





MISSION-CRITICAL SOLUTIONS

EMPOWER YOUR AGENCY TO OPERATE
AT THE HIGHEST STANDARD

- Policies & Updates – 170+ Policies
- Online Training – 1,500 Courses & Videos
- Grant Services – Hands-on assistance from grant experts
- Wellness Resources – Mobile wellness app

Learn more at [Lexipol.com](https://www.lexipol.com)

844-312-9500 | info@lexipol.com |   



CONFERENCE SPEAKERS & PRESENTATIONS



TRANSFORMATIONAL LEADERSHIP



Chief Dave Funkhouser
City of Kiel Police Department

Join Chief Dave Funkhouser, a 32-year veteran of law enforcement in Wisconsin, as he provides direction on becoming a dynamic leader by first becoming a leader of yourself; then developing that knowledge to transform yourself into an effective and powerful leader for your group or organization.

Using a blend of personal experiences, humor, and real-life examples, Dave Funkhouser will demonstrate and lead the attendees in digging deep to examining their own personal lives and feelings, with the intent of transforming their internalization process, thus developing a stepping stone to building, reinforcing and transforming their professional organizational and individual leadership skills.

Chief Dave Funkhouser has served in Wisconsin law enforcement for over 30 years including service as a Patrol officer, Detective, Lieutenant, and Captain for two suburban Milwaukee area police departments before being appointed Chief for the City of Kiel Police Department in 2005. More than half of his career Dave has served in multiple leadership roles in law enforcement. Dave has an AAS in Police Science and a BA in Criminal Justice Administration and is also a graduate of the basic and advance Police Executive Leadership program and the FBI's LEEDS program.

During his career, Dave has received numerous awards and recognition for his service in law enforcement including awards for the WTCA alumnus of the year, meritorious service, life-saving award, officer of the year, and the Wisconsin Attorney General's Leadership Award in 2016. In 2015, Dave served as the President of the WCPA and now currently serves on the WCPA's Mentoring and Nominating committees.



First responders across the country have been greatly underserved when it comes to investment management and advice. As a result, it has been the job of leadership to provide the education and services that members need. Anew Advisors looks to partner with first responder leadership to provide new or improved benefits to their members.

But where do you start? The financial world is vast and navigating it can be difficult. We aim to turn that uncertainty into confidence and that starts with knowing what you're up against. That's why at Anew Advisors we hire retired first responders to guide you through the process.

Step 1: Leadership – We believe that working with first responders needs to be a top-down process.

Step 2: Individual 1 on 1 Meetings – Once vetted, member education is at the forefront for most leadership.

Step 3: VEBA – One of the largest challenges faced by first responders is prefunding retiree healthcare to get from retirement to Medicare. It keeps members working longer, putting their financial and physical health at risk.

457 – As a key piece in retirement, it's important that members understand their 457 options.

**Proud Sponsors of the
2023 WPLF Winter Training Conference**





HOST CHIEF'S NIGHT

MONDAY, FEBRUARY 7TH

5:30PM - 7:30PM | EXHIBITION HALL

ALL EXHIBITORS & ATTENDEES WELCOMED!



All conference attendees and exhibitor booth personnel are welcomed to attend the 2023 WPLF Winter Conference's Host Chief's Night event being held on Monday, February 7th between 5:30pm and 7:30pm in the Exhibition Hall.

This event provides a wonderful opportunity for exhibitors to network with attendees in a casual environment. Complimentary appetizers, soda and tap beer will be served (cash bar available). Multiple door prize drawings will held during the event, including a drawing for a Glock Pistol donated by the Ray O'Herron Company.

To be admitted into the Host Chief's Night event you MUST show your exhibitor name badge or a guest pass. Guest passes to attend the event may be purchased at the Conference Registration Booth.



EVENT SPONSORS



flock safety

LIFELINE TECHNOLOGY CENTER AND SYSTEMS ACCEPTANCE LAB

BAYCOM's Lifeline Technology Center and Systems Acceptance Lab were designed for customers like you to see, interact and experience state-of-the-art technologies before investing in them. From its centrally located Madison-area location, we work with you side-by-side to demonstrate how today's technologies combine to make your operations safer and more efficient—today, tomorrow and into the future.



SEEING IS BELIEVING

Our Lifeline Technology Center (LTC) is designed to showcase the value of integrated voice, video and data ecosystems. During your visit, tell us about your most challenging safety and security concerns. We'll tailor a live-action scenario to demonstrate how these technologies work together to give you powerful, proactive capabilities when every moment matters.



DEPLOY WITH CONFIDENCE

If you've ever deployed an enterprise-wide system, you know it's critical to get the bugs worked out before the system is rolled out. **Within our new Systems Acceptance Lab, you are encouraged to test drive systems** that have been configured to meet your needs, allowing you to give feedback and make changes long before the technologies are deployed in the field.



GAIN PEACE OF MIND

Once your system is deployed, we continue to support you through our service agreement program. SystemGuard™ is customized to meet your needs and can include repair, preventive maintenance, tuning and testing of equipment for optimal performance or providing software and firmware updates. You also get priority status, minimizing the potential for operational disruption if an issue arises.



IT WILL WORK.

Our Lifeline Technology Center and Systems Acceptance Lab represent the natural extension of our brand promise: It Will Work. We've done the research, we have the experience and we're in this together. Let's develop a lifetime partnership that begins in our Lifeline Technology Center.

REACH OUT TO JOIN US TODAY.

FOR MORE INFORMATION ABOUT THE LIFELINE TECHNOLOGY CENTER:

✉ lifelinetechcenter@baycominc.com

☎ 800.726.5426



NON-DENOMINATIONAL PRAYER BREAKFAST



TUESDAY, FEBRUARY 7TH
7:15AM - 8:15AM | AFRICA BREAKOUT ROOM 50
ALL EXHIBITORS & ATTENDEES WELCOMED!

All conference attendees and are invited to join us Tuesday, February 7th for our 10th Annual Non-Denominational Prayer Breakfast sponsored by Police & Sheriff's Press for fellowship, music and inspiring message by our special guest speaker Paul Butler.



Paul Butler | Motivational Speaker

Paul Butler is an international renowned motivational speaker and entertainer with 27 years of law enforcement service. Paul became the Chief of Police of the Aynor Police Department at 22 years of age, making him the youngest police chief in the history of South Carolina.

As Chief Deputy of the Horry County Sheriff's Office, he was selected to attend the FBI National Academy in Quantico, Virginia in 2005 for the 220th Session. This 10-week, executive level course was host to 250 attendees from all 50 states and 29 countries around the world. Paul was selected by his class to be their graduation day speaker alongside then-FBI Director Robert Mueller. He continues to serve as the official Master of Ceremonies for the FBI National Academy Associates during their annual training conferences, which are held throughout North America.



TICKET PRICE: \$5.00 EA.

TICKETS ARE AVAILABLE FOR PURCHASE AT EXHIBITOR AND ATTENDEE REGISTRATION BOOTHS UNTIL 3:30PM ON MONDAY.

Your sole source for secure credentials

Protecting the most valuable
ID in the world...YOURS

FREE SOFTWARE

NO SET-UP FEE

NO MINIMUM ORDER

ONE DAY PROCESSING



Over 5,000 Satisfied
Agencies Worldwide

Police and Sheriffs Press, Inc.
204 E. Third Street, Vidalia, GA 30474
Contact: (912) 537-0780
Website: www.pasp365.com



EXHIBITOR PASSPORT PROGRAM



Participate for Your Chance to Win an Insignia 58" Class F30 LED 4K UHD Smart Fire TV!



INSIGNIA

How to Participate|

Collect a signature from a single representative of each Exhibitor listed on the "Exhibitor Passport Program Sign-Off Form."

Provide the completed Form to the WCPA/WPLF Booth #901 by **NO LATER THAN 2:45pm** on Tuesday, February 7th.

The TV Prize Winner will be selected at random from Forms submitted and will be announced in the Exhibition Hall during Tuesday's afternoon break at approximately 3:00pm.

Selected prize winner must be present when announced to claim prize.

Verizon Frontline

The advanced network and technology for first responders

When disaster strikes, citizens look to federal, state, and local emergency responders to return their lives and communities to normalcy. While members of public safety agencies put their lives on the line every day, Verizon delivers on the promise to provide reliable connectivity and communications for public safety.

Scan to learn more.

verizon.com/publicsafety
Data usage applies for QR/download use.

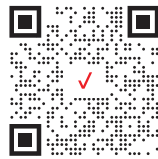

verizon[✓]

IACP 2023

OCTOBER 14-17 | SAN DIEGO, CA



SCHEDULE OF EVENTS

TUESDAY, FEBRUARY 7TH



Start Time	End Time	Description	Location
7:15 AM	8:15 AM	10th Annual Non-Denominational Prayer Breakfast <i>Featuring Special Guest Speaker: Mr. Paul Butler</i> <i>Sponsored by: Police & Sheriff's Press</i>	Africa Breakout Room 50
7:00 AM	8:00 AM	Complimentary Continental Breakfast	Exhibition Hall
8:00 AM	3:00 PM	Attendee & Exhibitor Conference Registration	Registration Africa East
8:30 AM	9:00 AM	"Annual Membership Meeting" <i>(continued from Monday)</i> <i>featuring 3rd Vice-President Election Results,</i> <i>WPLF Board Updates, vote for proposed bylaw changes,</i> <i>& WCPA Legislative Updates</i>	Rooms A, B, G & H
9:00 AM	9:15 AM	"Wisconsin Act 75 - Duty to Intervene & Off-Duty Considerations" <i>Presented by Chief Glenn Rehberg (Cornell Police Dept.)</i>	
9:00 AM	3:30 PM	Exhibition Hall/Booth Displays Open	Exhibition Hall
9:15 AM	10:00 AM	"Waukesha Christmas Parade Case Study" <i>Presented by Chief Daniel Thompson with</i> <i>Asst. Chiefs Tom Wagner & Ron Oremus, &</i> <i>Captain Daniel Baumann (Waukesha Police Dept.)</i>	Rooms A, B, G & H
10:00 AM	10:45 AM	Break with Exhibitors <i>Sponsored by: FirstNet, Nuance Communications and</i> <i>Galls</i>	Exhibition Hall
10:45 AM	12:00 PM	"Waukesha Christmas Parade Case Study" <i>(continued)</i>	Rooms A, B, G & H
12:00 PM	1:00 PM	Lunch with Exhibitors <i>Sponsored by: Symbol Arts and Verizon</i>	Exhibition Hall
1:00 PM	2:30 PM	"Waukesha Christmas Parade Case Study" <i>(continued)</i>	Rooms A, B, G & H
2:30 PM	3:15 PM	Break with Exhibitors <i>Sponsored by: i-PRO Americas, Inc. and T-Mobile</i>	Exhibition Hall
3:15 PM	4:30 PM	"Waukesha Christmas Parade Case Study" <i>(continued)</i>	Rooms A, B, G & H
6:00 PM	8:30 PM	Association President's Dinner Reception and Banquet <i>featuring "Leadership for a Lifetime" presentation by</i> <i>Mr. Paul Butler special guest motivational speaker</i> <i>Sponsored by: Lexipol</i>	Rooms A, B, G & H



CONFERENCE SPEAKERS & PRESENTATIONS



WISCONSIN ACT 75 - DUTY TO INTERVENE & OFF-DUTY CONSIDERATIONS



Chief Glenn Rehberg
Cornell Police Department

Wisconsin Act 75 which was enacted on August 6th, 2021, but went into effect January 1st, 2022 states that when police officers in the state of Wisconsin use force they shall make every effort to preserve and protect human lives. When Wisconsin police officers do use force, they must act in good faith and assess beforehand:

1. The seriousness of the crime that is being alleged.
2. Whether or not the suspect poses an imminent threat to the safety of the public or other police officers.
3. Whether or not the suspect is actively resisting arrests or actively attempting to evade arrest by trying to leave the scene.

This act also mandates officers to intervene to stop another police officer from using excessive or unreasonable force and report the findings to his or her immediate supervisor as soon as possible after the occurrence. This presentation being provided by Chief Glenn Rehberg of the Cornell Police Department will provide additional details relating to Wisconsin Act 75 as well as discuss off-duty factors officer should consider and provide training resources.

Prior to becoming Chief of the Cornell Police Department, Glenn Rehberg spent 10 years as a Senior Training Officer in the Wisconsin Department of Justice's Training and Standard Bureau where he led the Tactical Skills, Scenario and Tactical Emergency Casualty Care advisory committees. His work focused on curriculum development and instructor training in firearms, use of force, high-risk patrol tactics, scenario training/testing/safety and the Incident Command System.

A powerful total agency solution



VIRTUAL ACADEMY.

Because...You Deserve More

We know you are tasked with responsibilities beyond your role, so we support you!

Virtual Academy recognizes you deserve more and makes managing your agency easier with a total agency solution.

- **Communicate**
Keep your officers informed and safe across shifts with the most relevant updates instantly in one location.
- **Customize**
Deliver your agency's specific training in an online classroom to ensure consistency in delivery and learning concepts.
- **Report**
Monitor compliance with customized agency reports in a few clicks.
- **Train**
Allow your trainers to focus on specialized techniques and skills while utilizing our online classroom for hundreds of hours of courses and roll calls.

Contact us to learn about Certification Tracking and all that we offer.



WCPA
STRATEGIC
PARTNER

Come see me at booth #307!



Heather Wall

731-446-7193

heather.wall@virtualacademy.com



CONFERENCE SPEAKERS & PRESENTATIONS



WAUKESHA CHRISTMAS PARADE CASE STUDY



Chief Daniel Thompson
Waukesha Police Dept.

On November 21, 2021 tragedy struck the City of Waukesha when a driver of a sport utility vehicle (SUV) killed six people and injured 62 others by hitting participants and observers at the annual Christmas parade. This presentation will provide detailed information from a first-hand perspective about how this chaotic and dreadful event unfolded, incident command structure, technologies used to reduce confusion, management of public information and the media, as well as post event wellness and resiliency strategies. This presentation is being provided by various officers from the Waukesha Police Department including, Chief Daniel Thompson, Assistant Chiefs Tom Wagner and Ron Oremus as well as Captain Daniel Baumann.



Asst. Chief Thomas Wagner
Waukesha Police Dept.

Chief Daniel Thompson began his law enforcement career with the Milwaukee Police Department in 1991. During his time in patrol, he was selected for special assignments with the Gang Squad and Metro Drug Unit. In 1999, he was promoted to Detective. As a Detective, he worked five years in High-Intensity Drug Trafficking Area (HIDTA) task force. He was also selected to become a member of the Milwaukee Hazardous Devices Unit (Bomb Squad). Afterwards, he then worked in the Homicide Unit and was assigned a full-time agent to the FBI's Joint Terrorism Task Force (JTTF).



Asst. Chief Ron Oremus
Waukesha Police Dept.

After being promoted to a Lieutenant, Chief Thompson was assigned to the Intelligence Fusion Division and became the Director for Southeastern Wisconsin Threat Analysis Center (STAC) (Southeastern Wisconsin Threat Analysis Center). He was additionally assigned to the Homicide Unit as a Lieutenant. When promoted to Captain, he led the Fusion Division in leveraging technology and partnerships with state, federal, and local agencies, as well as the private sector. In 2019, Thompson was promoted to Inspector of Police and oversaw operations of the City of Milwaukee between 4:00pm to 8:00am. He was also assigned to manage and lead the team to host the 2020 Democratic National Convention. In May of 2020 Thompson was sworn in as Chief of Police for the City of Waukesha.



Capt. Daniel Baumann
Waukesha Police Dept.

Assistant Chief Tom Wagner has over 25 years of law enforcement experience and is charged with the management of operations at the Waukesha Police Department. At the time the parade tragedy transpired, he was assigned as the Captain of the Criminal Investigations Division. Assistant Chief Wagner has worked in several different positions including: Detective, Patrol Sergeant, CID Sergeant, Lieutenant of Detectives, Captain of Special Services, Captain of the Criminal Investigations Division, and Interim Chief of Police. He currently serves as an Executive Member of the Joint Terrorism Task Force (JTTF) and has considerable experience as a member of the Milwaukee Area Investigative Team (MAIT).

Assistant Chief Ron Oremus has been in law enforcement for over 30 years and began his career with the City of Waukesha Police Department in 1995. He has over 20 years' experience on the Waukesha Police Tactical Unit and retired from the SWAT team in 2020 as a Tactical Commander. Oremus came up through the Patrol Division and was eventually assigned as a Lieutenant in the Criminal Investigation Division in 2009. He spent five years in both the Criminal Investigation and the Patrol Divisions as a Captain before being transferred to the Special Services Division, where he was assigned at the time of the Christmas Parade incident.

Assistant Chief Oremus recently assisted with planning a \$18 building expansion, coordinated displacement relocation for the entire staff during the 15-month process; to include a fully functional emergency dispatch center. He currently is responsible for Open Records, accreditation, policies, the department budget and overseeing the Special Services Division.



COMMUNITY SECURITY SOLUTIONS

www.communitysecuritysolutions.com

Community Security Solutions (CSS) is an organization combining the expertise of veteran law enforcement officers, administrators and trainers in combination with a fire department director and military veterans.

CSS provides innovative, discreet and highly confidential consulting and contracting services to Individuals, Businesses and Communities.

CSS strengths and core competencies rest with the individuals involved in the company. The combination of administrators, veterans and retained associates brings legitimacy and professionalism to our clients. We take great pride in adhering to the most strict ethical and confidential standards. We customservice to our clients' needs.

SERVICES



Corporate Fraud Examinations/Investigative Research/Organizational Internal Investigations/ Business Due Diligence Examinations



Municipal (City, Village, Towns) Police/Fire & Public Administration Executive Recruitment/ Selection Processes to include Police & Fire Chiefs/ Command Staff & Civilian Administrators



Critical Incident Reviews



Personnel/Physical Asset Protection Consulting



Hostile Customer Training/Active Shooter Training/WI CCW Certification/ Individual Live Fire Weapons and Tactics



Private Organizational Infrastructure & Critical Asset Protection Analysis



Law Enforcement & Fire Organizational Assessments & Training



School/Educational Institution Residency Investigation



Official Advisory Services Provider of the
Wisconsin Chiefs of Police Association (WCPA)

Wisconsin Licensed Private
Investigation Agency (Fully Insured)



CONFERENCE SPEAKERS & PRESENTATIONS



LEADERSHIP FOR A LIFETIME: HOW THE PAST PREPARES US FOR THE FUTURE



Chief (ret.) Paul Butler
Motivational Speaker

This motivational presentation, provided by international renowned speaker, presenter, instructor, and entertainer Paul Butler, will cover what it takes to be a good professional and highlight the power of being a good person. Paul will illustrate how to take individual talents and apply them to the group setting to make an unstoppable and productive team. It is Paul's strong belief that the ability to lead is present in everyone, regardless of their rank in an organization or irrespective of their situation in life. There are common characteristics that respected people and effective leaders share - most of these traits are developed by the individual rather than through the position they hold. This presentation will detail some of these most important leadership traits, as well as how each individual can use the lessons of yesterday to overcome the challenges of today and capitalize on the opportunities of tomorrow.

Paul Butler holds a Bachelor's Degree in Communication with a concentration in Culture and Communication, as well as an Associate's Degree in Criminal Justice. He excels in the areas of motivation, leadership, customer service, and attitude empowerment. During his 27 years of law enforcement, he has been a public servant, training officer, sergeant, crisis negotiator, chief of police, and chief deputy. These opportunities have given him a unique perspective on a vast array of situations and circumstances that many people find themselves in every day. These experiences have helped him to develop the answers to questions and cures to problems most people are facing at work and in life on a continual basis.

Paul became the chief of police of the Aynor Police Department at 22 years of age, making him the youngest police chief in the history of South Carolina. Born and raised on a small farm, his parents served as examples of hard work, common sense, personal responsibility, and respect for self and others. This has played heavily in his success in life and within each organization in which he has served. He believes the power of a positive attitude can take you to the top or help you simply find happiness and pride in the current role you fill. A healthy attitude is often the key to both personal and professional success - this has certainly been the key to Paul's success.

As Chief Deputy of the Horry County Sheriff's Office, he was selected to attend the FBI National Academy in Quantico, Virginia in 2005 for the 220th Session. This 10-week, executive level course was host to 250 attendees from all 50 states and 29 countries around the world. Paul was selected by his class to be their graduation day speaker alongside then-FBI Director Robert Mueller. He continues to serve as the official Master of Ceremonies for the FBI National Academy Associates during their annual training conferences, which are held throughout North America.





PRESIDENT'S RECEPTION & DINNER BANQUET



Tuesday, February 7th | Rooms A, B, G & H
6:00pm - 8:30pm
All Conference Attendees Welcome



Chief Steven Roux
Rice Lake Police Dept.

The outgoing WCPA President Steven Roux invites all Conference Attendees to attend the Association President's Reception and Dinner Banquet sponsored by Lexipol.

In addition to a wonderful meal, those in attendance may also look forward to:

- WILEAG Department Awards and Recognitions
- Presentation of Past President Award
- Swearing in of New WCPA President Chief Dean Smith (Oshkosh Police Dept.)
- Banquet Prize Drawings including a chance to win a DEZ AR-15 5.56 Nato Caliber Rifle donated by DEZ Tactical Arms
- Inspirational Message by Special Guest Speaker Chief (ret.) Paul Butler



EVENT SPONSOR



LEXIPOL



HOW ONE OFFICER CAN SEE 17 BLOCKS ALL AT ONCE

MORE THAN TOUGH DEVICES
HARDWARE > SOFTWARE > SERVICES

Learn more about how TOUGHBOOK® rugged mobile solutions support law enforcement.

[1.888.245.6344](tel:18882456344) | TOUGHBOOK.com | TOUGHBOOK@us.panasonic.com



SCHEDULE OF EVENTS

WEDNESDAY, FEBRUARY 8TH



Start Time	End Time	Description	Location
7:00 AM	8:00 AM	FBINAA WI Chapter Breakfast <i>NOTE: For FBINAA Members Only</i> <i>Sponsored by: Panasonic</i>	Africa Breakout Room 50
8:00 AM	8:15 AM	"WI Attorney General Updates" <i>Presented by WI Attorney General Josh Kaul</i> <i>(WI Dept. of Justice - Office of the Attorney General)</i>	Rooms A, B, G & H
8:15 AM	8:45 AM	"Wisconsin's New High-Risk Vehicle Contact Model and WI DOJ Training & Standards Update" <i>Presented by Mr. Ronald Betley</i> <i>Education Consultant</i> <i>(WI Dept. of Justice - Training and Standards Bureau)</i>	
8:45 AM	9:15 AM	"MOCIC & WI LEDR Team Updates" <i>Presented by Micheal Sasse</i> <i>(MOCIC - WI Representative and WI LEDR President)</i>	
9:15 AM	9:30 AM	Break	-
9:30 AM	10:00 AM	"Federal Civil Rights" <i>Presented by Attorney Christopher Ladwig</i> <i>Assistant United States Attorney -</i> <i>(Eastern District of Wisconsin)</i>	Rooms A, B, G & H
10:00 AM	11:00 AM	"Legal Updates" <i>Presented by Asst. District Attorney Annie Jay</i> <i>(Dane County District Attorneys Office)</i>	
11:00 AM	12:00 PM	"Legal Updates" <i>Presented by Attorney Kyle Gulya</i> <i>(von Briesen & Roper, S.C.)</i>	

NOTE: Complimentary continental breakfast not available on Wednesday, however, coffee and danish will be available in the training room.

Conference schedule of events are subject to change without notice.



CONFERENCE SPEAKERS & PRESENTATIONS



WISCONSIN ATTORNEY GENERAL LEGAL UPDATES



Attorney General Josh Kaul
WI DOJ

Josh Kaul was sworn in as Wisconsin's 45th Attorney General on January 7, 2019. Josh's top priority is public safety. Under his leadership, the Wisconsin Department of Justice has worked to combat the opioid epidemic and the increasing use of meth in Wisconsin, to make our schools and communities safer from gun violence, and to pass legislation designed to prevent Wisconsin from having another backlog of untested sexual assault kits. Josh is also committed to fighting for clean and safe drinking water and against climate change and to protecting the rights of Wisconsinites.

Josh served as a federal prosecutor in Baltimore, where he prosecuted murderers, gang members, and drug traffickers. After moving back home to Wisconsin, he worked to protect our right to vote, going to court to challenge restrictions on voting.



GENERAL LEGAL UPDATES



Asst. District Attorney Annie Jay
Dane Co. D.A.'s Office

Annie Jay recently joined the Dane County District Attorney's Office as an Assistant District Attorney prosecuting serious felony cases. Ms. Jay previously worked as an Assistant Attorney General in the Wisconsin Department of Justice and as an Assistant District Attorney in the Kenosha County District Attorney's Office. In addition to prosecuting cases, Ms. Jay also trains prosecutors and law enforcement across Wisconsin. In 2021, she received an award from the International Homicide Investigators Association for her successful prosecution of a bodiless homicide in Portage County. Ms. Jay received the Lee and Lynn Copen Family Justice Award from Women and Children's Horizons in Kenosha for her work with victims of domestic violence and sexual assault. She has a Bachelor's degree in Political Science with a minor in German from the University of Delaware and received her J.D. from the University of Wisconsin Law School.



Attorney Kyle Gulya
von Briesen & Roper, S.C.

Kyle Gulya is a Shareholder in the Labor and Employment Law Section of von Briesen & Roper, S.C. Kyle frequently presents on labor-and employment-related issues throughout Wisconsin and nationally. Kyle has extensive experience involving the unique employment -and labor-related issues faced by Police Departments, Fire Departments, Sheriff's Departments and Police & Fire Commissions. Kyle works closely with law enforcement professionals regarding management-side labor-and employment-related issues. Kyle is very proud of his relationships with the WCPA, the WPLF and the Wisconsin Fire Chiefs Education Association.

Kyle has been recognized on several occasions as a Rising Star by Wisconsin Super Lawyers® in Employment & Labor Law. Kyle has served on the Board of Directors for the Labor and Employment Law Section of the State Bar of Wisconsin.





See the **Chorus Intelligence Suite (CIS)** in action at the WPLF Winter Training Conference.

The most advanced data search, analysis, cleansing and evidence enrichment tools, in the world.

One Platform, One Dashboard



chorusintel.com | NAinfo@chorusintel.com



CONFERENCE SPEAKERS & PRESENTATIONS



WISCONSIN'S NEW HIGH-RISK VEHICLE CONTACT MODEL AND WI DOJ TRAINING & STANDARDS BUREAU UPDATE



Mr. Ron Betley
Education Consultant
WI DOJ Training & Standards Bureau

This presentation is being provided by Mr. Ron Betley, a Law Enforcement Education Consultant with the WI DOJ's Training and Standards Bureau who will explain changes to the state's High-Risk Vehicle Contact (HRVC) procedure and the various data sets other information that were evaluated which led to the state's decision to make these procedural changes. He will also detail the new HRVC procedure, provide a timeline for its implementation as well as present additional Training and Standards Bureau updates.

Prior to joining the WI DOJ, Ron Betley was employed as a law enforcement officer with the Rock County Sheriff's Office in Janesville. He retired in 2019 after over 27 years of service. At the time of his retirement, he held the rank of Detective and served as a lead firearms and use-of-force instructor. He also served as a team leader with the Sheriff's Office SWAT team and was the team's firearms training range master and tactics instructor. Ron's primary focus and area of expertise is in the tactical skills which includes Defensive and Arrest Tactics (DAAT), Firearms, Tactical Response, and their corresponding instructor courses. Ron also advises the WI DOJ on law enforcement use-of force, CCW and HR-218 issues.

Additionally, Ron was a Wisconsin LESB certified Firearms and Vehicle Contacts Master Instructor Trainer and Range Master for the Blackhawk Technical College Law Enforcement Academy in Janesville Wisconsin. He also instructed DAAT, Tactical Response, and other general topics in the academy.

During his law enforcement career, Ron has attended countless hours of advanced level investigative and tactical training. He has amassed a great deal of first-hand operational experience as a criminal investigator, tactical officer, tactical skills instructor and is a court recognized expert witness in firearms and tactical training.





DESIGNED BY ENGINEERS – PERFECTED BY MOTOR OFFICERS.

HIGHLIGHTS

- Mechanical Adjustable Actuation Clutch
- Limited 3 year, 60,000 mile factory warranty

RIDER SAFETY ENHANCEMENTS

Standard and cornering-enhanced ABS, electronically linked braking, traction control system as well as TPMS, vehicle hold control and drag-torque slip control.

MILWAUKEE-EIGHT® 114

Delivers up to 39% more power when compared to the Original Equipment engine configuration.

Visit [H-D.com/police](https://www.harley-davidson.com/police) to learn more.

©2022 H.D. or its affiliates. HARLEY-DAVIDSON, HARLEY, H.D. and the Bar and Shield Logo are among the trademarks of H.D. U.S.A., LLC.





CONFERENCE SPEAKERS & PRESENTATIONS



MOCIC & WI LEDR UPDATES



Michael Sasse
MOCIC - WI Law Enforcement Coordinator and
WI LEDR President

This presentation is being provided by Michael Sasse who currently serves as the Wisconsin Law Enforcement Coordinator for the Mid-States Organized Crime Information Center (MOCIC) as well as the president of Wisconsin's Law Enforcement Death Response Team (WI LEDR). MOCIC is one of six Regional Information Sharing Systems (RISS) Centers in the United States. MOCIC promotes officer safety by assisting local, state, federal and tribal criminal justice agencies in working together to combat multi-jurisdictional criminal activities by facilitating inter-agency intelligence information sharing. MOCIC also provides adaptive solutions and services including criminal intelligence analysis, computer forensics, confidential funding, equipment loans and training services. In this presentation, Michael will provide information about the many resources that are available from MOCIC, most of which are free for members. Michael will also be discussing his new role as president of the WI LEDR as providing updates about new upcoming WI LEDR projects.

Michael Sasse's law enforcement career began in 1991 with the Waupaca County Sheriff's Office, where he worked as Patrol Deputy and as Investigator, attaining the rank of Detective Sergeant. In 2001, he joined the Wisconsin Department of Justice's Division of Criminal Investigation (DCI) as a Special Agent where he investigated narcotics crimes with specializing in undercover operations. Michael was the first narcotics detection K-9 handler in DCI and worked for eight years with his partner "Harry" and an additional five years as homicide/cold case Investigator. In 2014, Michael was promoted to Special Agent in Charge (SAIC) and was assigned to oversee all operations in the DCI-Appleton office which covered 22 Wisconsin counties. As the SAIC, he was responsible for supervising investigations involving narcotics, major crimes, officer-involved deaths, white collar crimes and government corruption. In 2018, Michael was promoted to Deputy Administrator of the DCI where he served until his retirement in 2021. After his retirement from the DCI, Michael became the Wisconsin Law Enforcement Coordinator for MOCIC.



Visualize the Future of Traffic Safety

Let data sophistication take you there

VISIT LEXISNEXIS® COPLOGIC™ SOLUTIONS BOOTH #408
AT THE 2023 WPLF WINTER TRAINING CONFERENCE & EXPO

Visualize safer roadways in your community

Get fast access to visualizations of hyper-current crash data and analytics — maps, graphs and illustrated dashboards – to help your agency save more lives.

No matter where you are on the road to saving more lives, we can meet you there and help take you where you want to be.

Discover how by visiting us at the LexisNexis® Coplogic™ Solutions Booth #408 at the WPLF Winter Training Conference and Expo.

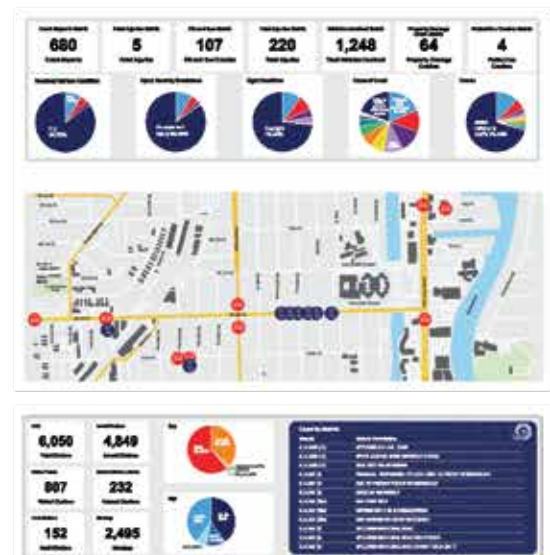

Sample agency data





CONFERENCE SPEAKERS & PRESENTATIONS



FEDERAL CIVIL RIGHTS



Attorney Christopher Ladwig
Assistant U.S. Attorney
Eastern District of Wisconsin

This presentation is a part of the "Wisconsin Together" initiative announced by the FBI Milwaukee Field Office and the United States Attorney's Office in the Eastern District of Wisconsin in December or 2021. Under this initiative, the FBI and the U.S. Attorney's Office are seeking to reduce hate crime and civil rights violations by engaging with local law enforcement partners and key stakeholders in the form of civil rights seminars and trainings with the goal of the understanding of law enforcement efforts to address civil rights issues and develop proactive strategies for identifying and addressing trends in this field.

This presentation is being provided Christopher J. Ladwig who was sworn in as an Assistant United States Attorney in February 2016. Chris currently works in the Criminal Division in the United States Attorney's Office in the Eastern District of Wisconsin. In 2018, Chris was assigned to the Eastern District of Wisconsin's Project Safe Neighborhoods (PSN) program and as the Civil Rights Coordinator.

As Civil Rights Coordinator, Chris works with the FBI and local law enforcement to identify federal civil rights and hate crime violations. Chris also co-created the Wisconsin Together Program - a civil rights seminar to train police and the public on federal civil rights and hate crimes laws.

As the PSN Coordinator, Chris has worked with federal and local law enforcement agencies in identifying and prosecuting the southeastern region's most prolific firearm offenders, increasing federal impact on firearm and gang-related violent crime in Milwaukee, and enhancing proactive and preventative measures to reduce violent crime, such as prisoner reentry.

Prior to working with the U.S. Attorney's Office, Chris was an Assistant District Attorney in the Milwaukee County District Attorney's Office from 2008 - 2015. For several years, Chris worked as Milwaukee Police District Three Community Prosecutor and the Near West Side Community Prosecutor. Chris collaborated on several proactive crime reduction initiatives involving violent drug and gun crime, prostitution and human trafficking, vacant property improvement, prisoner U.S. DOJ's National Community Prosecution Innovative Community Engagement award for his work in Milwaukee's neighborhoods.

Chris graduated, with Distinction, from the University of Wisconsin-Madison in 2001 with a B.A. in Political Science. He earned his law degree from the University of Wisconsin Law School in 2007, where he graduated cum laude.



TRUSTED BADGE SECURITY.

The diagram illustrates an Iron Harbor Police ID badge with several security features:

- Holo-Met™ Metalized Security Print:** Located at the top of the badge.
- Mezzo-Tinto 2D Security Print:** A grid of small, repeating patterns.
- Guilloche Print:** A decorative, wavy pattern on the left side of the badge.
- Security Micro-Text:** Small text integrated into the badge's design.
- Micro-Print State Emblem:** A small version of the state emblem on the left side.
- Tamper Evident Image-on-Image™ Security Print:** A feature where the badge's image is printed over itself.
- Metalized Ghost Image:** A smaller, semi-transparent version of the badge on the right side.

The badge itself features the following text and graphics:

- IRON HARBOR POLICE** (top and bottom text)
- EST. 1882** (on the right side)
- IRON HARBOR POLICE** (on the left side)
- IRON HARBOR POLICE** (center text)
- Richard Smithfield** (name)
- Lieutenant, Badge #184** (rank and badge number)
- Precinct SA14502B** (precinct information)
- ZF15AC** (identifier)
- IRON HARBOR POLICE** (small badge graphic)
- IRON HARBOR POLICE** (ghost badge graphic)

BOOTH NUMBER 9. FREE DEMONSTRATIONS.

www.rtaiprinters.com
1 (888) 465-6638
Minneapolis, MN USA



RTAI600™ Security ID Printer

Names and Images are fictitious and for illustration purposeonly.



EXHIBITION HALL FLOORPLAN



EXHIBITION HALL DATES & TIMES

Monday, February 6th
9:00am - 7:30pm

Tuesday, February 7th
9:00am - 3:30pm



Conference Attendee, Exhibitor or Guest Pass Name Badge Required for Entry

flock safety

One Platform to Unite and Protect Your Whole Community



**This is the single
greatest change since
DNA - what this system
does is a game-changer.**

- Chief Matt Murray
Yakima Police Department



ALPR

Get objective leads with cameras that see like a detective.

Audio Detection

Pair with ALPR to uncover more evidence than just shell casings.

Real-Time Intelligence

Layer sensors and data on a single screen to increase situational awareness and clearance rates.

Scan to
Learn More





ALPHABETICAL EXHIBITOR LIST



Company	Booth #	
5.11 Tactical.....	511	
Adorama Drones.....	700	
Advanced Security Technologies, LLC.....	624	
AdvaTech Systems.....	322	
AED Patrol PC.....	V111	
Aguila Ammunition/TXAT, LLC.....	308	
All Traffic Solutions.....	101	
American Military University.....	703	
Anew Advisors.....	325	
AnyGlide.....	818	
Architectural Design Consultants, Inc.....	121	
Axon.....	519	
Baycom.....	418	
Belco Vehicle Solutions, LLC.....	V711	
Bernie's Equipment Co., Inc.....	938	
Billy Graham Evangelistic Association.....	718	
Blauer Manufacturing.....	323	
Blue Circle Consulting.....	622	
Bradford Systems.....	922	
Camosy Construction.....	707	
Charter Communications.....	507	
Chorus Intelligence.....	505	
Community Security Solutions, LLC.....	926	
Concordia University Wisconsin.....	103	
Core Technology Corporation.....	305	
Cradlepoint.....	804	
Critical Response Group.....	914	
CTech Manufacturing.....	V301	
Custom Service Information, LLC.....	706	
CVMIC.....	607	
DATAMARK.....	912	
Decker Supply Co., Inc.....	129	
DEZ Tactical Arms, Inc.....	208	
E/M Wave Inc.....	117	
Eagle Engraving, Inc.....	A001	
Emergency Automotive Technologies, Inc.....	V615	
Emergency Communications Systems.....	125	
Ewald Auto Group.....	V311	

Company	Booth #	
Extra Duty Solutions.....	605	
Federal Signal.....	V125	
FGM Architects.....	603	
Fight Crime: Invest in Kids.....	216	
Fire Suppression Solutions, LLC.....	316	
FirstNet Built with AT&T.....	521	
FlockSafety.....	517	
Ford Motor Company.....	V715	
Frontline Public Safety Solutions.....	306	
Galls.....	523	
Gamber Johnson.....	424	
GenComm.....	V116 & V118	
General Fire Equipment Co., Inc.....	V211	
General Motors Fleet.....	V201	
GETAC.....	623	
Glock, Inc.....	619	
GoRhino.....	816	
Harley-Davidson Motor Company.....	501	
Havis.....	V225	
Herzing University.....	200	
Hoopster Performance Graphics, Inc.....	716	
IdentiSys.....	222	
International Conference of Police Chaplains.....	220	
Intoximeters.....	119	
i-PRO Americas Inc.....	416	
Jason Ganiere, CFP at IAG Wealth Partners.....	122	
Kiesler Police Supply.....	617	
Laser Technology, Inc.....	318	
Law Enforcement Death Response Team (LEDR).....	600	
LE Torch Run for Special Olympics of WI.....	608	
LENS Equipment.....	701	
LensLock.....	708	
Lexipol.....	404	
LexisNexis Coplogic Solutions.....	408	
Mid-States Organized Crime Information Center.....	602	
Midwest Defense Solutions, LLC.....	5	
Midwest Public Safety.....	317	
Montel Technologies, LLC.....	800	

Supporting Business Member

Conference Event Sponsor

WCPA Partner



ALPHABETICAL EXHIBITOR LIST



Company	Booth #	
Motorola Solutions.....	503	
MPH Industries.....	709	
NAMI Wisconsin.....	723	
Napleton Chevrolet Buick.....	104	
National Child Safety Council.....	302	
Nielson Communications.....	319	
North Shore Bank.....	820	
Northland Business Systems.....	616	
Nuance Dragon Law Enforcement.....	414	
Off Duty Management.....	320	
Ogre Mfg., LLC.....	219	
Omnigo Software.....	105	
O-Sun Company.....	25	
Pace Scheduler, Inc.....	202	
Panasonic.....	422	
Paul Davis Restoration - SEWI.....	808	
Police and Sheriffs Press, Inc.....	PASP	
PowerDMS.....	509	
Precision Installations, Inc.....	V725	
Prepared.....	30	
PrintekMobile.....	218	
RACOM Corporation.....	822	
Ray O'Herron Co., Inc.....	513	
RJ Wagner Marketing.....	719	
RTAI Printers.....	9	
Safe Haven Defense.....	920	
Seiler Instrument - Geospatial Division.....	23	
Sig Sauer.....	3	
Smarts VR.....	206	
SoundOff Signal.....	V114	
Stalker Radar.....	102	
Stanard & Associates.....	903	
Stellantis.....	V611	
Streichers.....	309	
Symbol Arts.....	910	
TC Networks, Inc.....	209	
TG3 Electronics, Inc.....	717	
The Uniform Shoppe of Green Bay, Inc.....	321	

Company	Booth #	
Thin Line Outfitters of Wisconsin, LLC.....	V115	
TKK Electronics.....	207	
T-Mobile.....	924	
Top Pack Defense, LLC.....	900	
Trailways Counseling.....	221	
TruckEquipment.....	V11	
TruckVault.....	V215	
Ultra Strobe Communications, Inc.....	V625	
UScellular.....	525	
UW-Platteville.....	618	
VapenSystems, Inc.....	108	
Verizon.....	406	
Vertex Unmanned Solutions.....	720	
Virtual Academy.....	307	
Visual Labs.....	109	
Waldorf University.....	304	
Waukesha County Technical College.....	203	
WCPA/WPLF.....	901	
WI DOJ - Internet Crimes Against Children Task Force... 107		
WI DOJ - Office of School Safety.....	217	
WI DOT - Bureau of Transportation Safety (BOTS).....	1	
WI Law Enforcement Accreditation Group (WILEAG)....	609	
WI Law Enforcement Analyst Network (WILEAN).....	204	
WI State Crime Stoppers, Inc.....	606	
Wisconsin Cops.....	604	
Wisconsin Department of Justice.....	601	
Wisconsin DOT - TIME Program.....	704	
Wisconsin DRE & SFST Program.....	721	
Wisconsin Lifeline - Family Services.....	722	
Wisconsin Lottery Security.....	621	
Wisconsin Professional Police Association.....	315	
Wisconsin Surplus Online Auction.....	100	
WReeves and Associates.....	V515	
WSITechnologies.....	225	
Xcel Energy.....	620	
ZeroEyes.....	916	
Zimmerman Architectural Studios, Inc.....	124	
Zoll Medical Corporation.....	705	

Supporting Business Member

Conference Event Sponsor

WCPA Partner



DOOR PRIZE DONATIONS



The WCPA and WPLF extends a special thanks to all Exhibitors for their generous Door Prize donations. All WCPA Members and guests registered for the Conference are automatically entered into Door Prize drawings. Door Prize drawing winners are randomly selected and announced during Conference Breaks, Lunches, Host Chief's Night and the President's Banquet.

If your name is announced as a Door Prize winner, you MUST be present at the event to claim your prize.

The following is a list of Door Prize donations that were confirmed in advance. This is a partial list as many Exhibitors choose to provide Door Prize donations on-site at Exhibitor Check-in.

FIREARMS

- DEZ Tactical Arms, Inc. (Booth #208): DEZ AR-15 5.56 NATO Caliber Rifle
- GLOCK, Inc. (Booth #619): Glock Pistol (model TBD)
- Kiesler Police Supply (Booth #617): Glock Pistol (model TBD)
- Ray O'Herron Company (Booth #513): Pistol (make and model TBD)
- Sig Sauer (Booth #3): Sig Sauer P365 Xmacro 9mm Pistol
- Top Pack Defense (Booth #900): Pistol (make and model TBD)

GENERAL DOOR PRIZES

- 5.11 Tactical (Booth #511): Misc. 5.11 Tactical Merchandise and Apparel
- Agulia Ammunition/TXAT, LLC (Booth #308): 1,000 rounds of Ammo (9mm 124 gr.) Gift Certificate (\$331.00 value)
- Bernie's Equipment Co., Inc./Tiffin (Booth #938): \$1,200.00 Gift Card for any Tiffin Police Product
- Camosy Construction (Booth #707): Whiskey
- Concordia University (Booth #103): Concordia T-shirt, Water Bottle and Other College SWAG
- CTech Manufacturing (Booth #V301): TopBox (Model TBD) (\$1,900.00 value)
- E/M Wave, Inc. (Booth #117): A WISCOM Wideband VHF Mobile Antenna & a VHF/UHF/700-800 Triband Mobile Antenna
- Fire Suppression Solutions, LLC (Booth #316): Fire Suppression Tool (FST)
- Harley-Davidson Motorcycles (Booth #501): Misc. Harley-Davidson SWAG
- Herzing University (Booth #202): Bottle of Wine and Gift Card
- LensLock, Inc. (Booth #708): Gift Card
- Midwest Defense Solutions, LLC (Booth #5): Custom Survival Armor Load Bearing Vest
- PrintekMobile (Booth #218): \$100.00 Amazon Gift Card
- Seiler Geospatial - Seiler Forensics- Seiler GeoDrones (Booth #23): Gift Card
- TC Networks, Inc. (Booth #209): (3) \$50.00 Amazon Gift Cards

DOOR PRIZES TBD

Architectural Design Consultants, Inc. (Booth #121) | Bernie's Equipment Co., Inc. (Booth #938)
 Blauer Manufacturing (Booth #323) | Core Technology Corporation (Booth #305) | CVMIC (Booth #607)
 Emergency Automotive Technologies (Booth #V615) | Getac (Booth #623)
 Jason Ganiere, CFP at IAG Wealth Partners (Booth #122) | Ogre Mfg. (Booth #219) | Omnigo Software (Booth #105)
 Safe Haven Defense (Booth #920) | Streicher's (Booth #309) | Trailways Counseling (Booth #519)
 Uniform Shoppe of Green Bay (Booth #321) | UW-Platteville (Booth #618) | Wisconsin Lifeline Services (Booth #722)
 Zimmerman Architectural Studios (Booth #124)



"CTech Manufacturing is very supportive of Law Enforcement and does an excellent job."

-Sheriff Mark Podoll | Green Lake, WI



CUSTOMIZE YOUR NEXT COPBOX CABINET® ONLINE

CTech.is/wisconsinpdsupport2022



NEW!





WCPA PARTNERSHIP PROGRAMS

The WCPA has Partnership Program agreements in place with trusted law enforcement technology, product, and service providers.

The WCPA benefits financially whenever a WCPA Members' agency procures products or services from any of the organizations featured below. The support received from these Partnership Programs not only helps to keep the WCPA economically viable, they also help ensure that we can continue to provide our members with the best training and resources available while allowing us to keep annual membership dues and conference registration fees to a minimum.

CRITICAL RESPONSE GROUP | COLLABORATIVE RESPONSE GRAPHICS®

WWW.CRGPLANS.COM



When an emergency occurs at a facility, hundreds of public safety professionals may respond, the majority of which will have little familiarity with the site. Almost two decades of After-Action Reports in the post-Columbine era point out that unfamiliarity with locations and an inability to communicate locations inhibited response times, closing on active assailants and evacuating casualties. Critical Response Group's Collaborative Response Graphics® (CRGs®) are designed to be simple maps - useable under stress - by anyone involved in an incident, from security personnel and facility administrators to dispatchers, responding officers and incident command, to communicate locations both outside and inside a facility!

POLICE & SHERIFF'S PRESS, INC. | SECURE CREDENTIALING

WWW.PASP365.COM



Police & Sheriff's Press (PASP ID) is proud to offer one of the most secure ID card platforms in the world today. PASP ID's patented Hologview® card stock features numerous overt and covert embedded security features such as: holograms, demetalized imaging, nano-text, black light core stock and multiple other security features making them virtually impossible to counterfeit. PASP ID's credentials are proudly manufactured in the U.S. and are used by over 5,000 federal, state and local government agencies worldwide. Their "print-for-you" service has a minimum order of one card, but they are also able to accommodate large contracts with needs for millions of cards. No matter your needs, PASP will work with you to create a custom solution.

STANARD & ASSOCIATES, INC. | PUBLIC SAFETY TESTING SERVICES

WWW.STANARD.COM



Since 2001, Standard & Associates (S&A) and the WCPA have partnered to provide off-the-shelf exams to help Wisconsin law enforcement agencies improve their selection processes. WCPA Members representing over 200 departments in Wisconsin have used entry level, promotional, dispatcher and detective/investigator exams provided by S&A.

The WCPA's partnership with S&A provides our Members with multiple benefits including:

- Need to Hire Proctors
- No Waiting for Test Results
- Quick Delivery
- Pay Only for the Actual Number of Exams Used

For additional information about the S&A/WCPA Partnership please contact Ray Appel (WCPA Executive Assistant) via email rappel@wchiefs.org or call 920-209-9472.

VIRTUAL ACADEMY | ONLINE PUBLIC SAFETY TRAINING

WWW.VIRTUALACADEMY.COM



VIRTUAL ACADEMY®

Virtual Academy gives agencies the ability to invest in more training by eliminating the time and travel expenses associated having to send officers and/or dispatchers to a physical, state training facility by providing the same quality training on a handheld device. Virtual Academy's training is provided by engaging and knowledgeable national experts via a virtual classroom. Unlike other programs, Virtual Academy's platform is intuitive making it easy to use, manage, track and create training records and departmental files. If help is ever needed, all users are provided with 24/7 access to Virtual Academy's U.S. based technical support team that boasts a 98%+ satisfaction rate and 94% one call resolution rate.

The State of Wisconsin has been proactive in measures to make our schools safer. 2017 Act 143 created the Office of School Safety and invested \$100 million in school safety initiatives. Additionally, Act 143 asked for all school districts to submit blueprints to the Office of School Safety, with many districts not fully complying.

For the majority of the schools in the state, however, school floor plans remain inaccessible to first responders during an emergency. They also do not reflect the current labeling of the school and lack critical information first responders need to know, like door numbers, hallway names, and key utilities.

CRGs solve this problem by providing a first responders with a simple communication and collaboration tool - accessible and useable under stress - to coordinate emergency response both outside and inside a building. CRGs enhance response time and improve command and control during an incident.



Each floor of a building gets a "Micro" CRG to coordinate response inside a building.



Each campus gets a "MACRO" CRG to coordinate outside of a building.



How it's used

Critical Response Group ensures approved first responders have access to current CRGs of your site every year, including the 911-Emergency Center and the SWAT unit that provide coverage of your area. We customize our integration to each specific agency to ensure the maps are accessible as possible.

About the Team

Our founders are a mix of decorated and combat-tested U.S. Military Special Operations veterans and senior law enforcement executives, which gives us a unique perspective on building and implementing Common Operating Pictures for domestic first responders. We are fully committed to introducing a solution that is not based on theory, but instead is mission proven.



WCPA PARTNERSHIP PROGRAMS

LEXISNEXIS® COPLOGIC™ SOLUTIONS | RISK.LEXISNEXIS.COM

As the WCPA's crash-reporting, LexisNexis® Coplogic™ Solutions offers LexisNexis® Police Reports at no cost to our Members' agencies. By making reports accessible online, 24/7, to authorized parties, this dynamic solution can help eliminate everyday inefficiencies and resource burdens associated with police report distribution. Moving the process online significantly reduces the amount of mail and counter traffic agencies experience. In addition, it can help agencies:

- Preserve resources and reallocate them to other law enforcement initiatives
- Easily track and monitor agency-wide report requests and sales
- Strengthen compliance with laws regarding the distribution of crash reports
- Access powerful Investigative Insights



LexisNexis® Police Reports also includes free access to other valuable services, including Investigative Insights about people, vehicles and incidents across the nation. Using this feature, which provides access to a database of 173 million pieces of data (consisting of 91 million person records, 82 million accident records, more than 35,000 accidents reports, and 62,000 VINs added daily) can help your officers, detectives and investigators better inform and accelerate their crime-solving efforts.

LEXIPOL | POLICY RESOURCE MANAGEMENT WWW.LEXIPOL.COM/LAW-ENFORCEMENT

Lexipol empowers first responders and public servants to best meet the needs of their residents safely and responsibly. Our solutions include Wisconsin state-specific policies, online learning, behavioral health resources, funding assistance, and news and information offered through the websites Police1, FireRescue1, EMS1, Corrections1 and Gov1. Lexipol serves more than 2 million public safety professionals in over 8,000 agencies and municipalities.



Lexipol is the expert in comprehensive, enhanced policy and training information and tools. Lexipol's policy services are designed to clearly advocate for the entire community, including first responders, public servants and residents. All while providing transparent and supported situational responses, the highest standards for conduct and clear direction for those on the front lines. Lexipol provides constitutionally sound policies that comply with all federal and state laws and are updated regularly, allowing any-sized department to have a team of experts at their fingertips.

COMMUNITY SECURITY SOLUTIONS | PROFESSIONAL, CONFIDENTIAL CONSULTING SERVICES WWW.COMMUNITYSECURITYSOLUTIONS.COM

Community Security Solutions (CSS) is a Wisconsin based organization that provides individuals, businesses and communities with a variety of customizable consulting and contracting services including:

- Executive Recruitment and Selection Processes for Municipal Police Chiefs, Fire Chiefs, Command Staff and Civilian Administrators
- Law Enforcement and Fire Organizational Assessments and Training
- Internal Organizational, Business Due Diligence and School/Educational Institution Residency Investigations
- Personal/Physical Asset Protection
- Corporate Fraud Examinations
- Private Organizational Infrastructure and Critical Asset Protection Analysis
- Hostile Customer Training
- Critical Incident Reviews
- Active Shooter Training
- Live Fire Weapons and Tactics
- WI CCW



As an organization composed of law enforcement officers, administrators, instructors, university/college security professionals, fire department directors and military veterans, CSS offers clients with professional, real-world solutions. CSS commitment to confidentiality and adherence to a strict ethical code are some of the many reasons they were selected to serve as the WCPA's official advisory services provider.



GENCOMM

PROUD TO SERVE LAW ENFORCEMENT

State, county, and municipal law enforcement officials rely on GenComm's expertise and capabilities for their mission critical communication needs. Whatever the situation, we keep our customers connected to the people and the information they need to protect themselves and others - wherever they may be.

A GenComm solution ensures the absolute best performance and reliability available. We also proudly install and service all of our products, with well-trained installation and service employees who provide quick and expert workmanship.

We salute all who serve in law enforcement. Let us help you make sure that your mission is a success.

WHAT WE PROVIDE

- Mobile Radios
- Portable Radios
- Dispatch Consoles
- Pagers
- Lights
- Partitions
- Push Bumpers
- K9 Transport
- Consoles
- Seat Covers
- Computer Docking Stations
- Networking, Laptops and Tablets



"Your company and employee dedication and hard work has not gone unnoticed. What a great team of individuals to work with as we formulated our plan for our squad car equipment install. They continually stayed in contact with me advising me of their process and progress every step of the way. This gave me a sense of security and eased the stress level that comes with the process. Your company is a great asset to the law enforcement world."

- Chief of Police, City of Manawa

Office: 608-271-4848

2880 Commerce Park Dr., Madison, WI 53719

gencomm.com

Madison, WI • Milwaukee, WI • Eau Claire, WI • Wisconsin Rapids, WI • McHenry, IL



BECOME A SUPPORTING BUSINESS MEMBER

The Wisconsin Chiefs of Police Association (WCPA) welcomes companies to join us in our mission of helping keep Wisconsin communities and Law Enforcement Officers safe by becoming a Supporting Business Member.

In addition to joining Wisconsin's oldest and largest network of law enforcement executive decision makers, WCPA Supporting Business Members are afforded multiple benefits which include:

- Ability to download WCPA's most current Member List which includes member's name, email address as well as agency name and mailing address
- Early access to WPLF Training Conference Online Exhibitor Conference Registration and \$50.00 Booth Discount
- Authorization to use of the "WCPA Supporting Business Member" Logo/Graphic on company's website and marketing materials
- Company logo with website link featured in the "Supporting Business Member" scrolling marquee on the WCPA's website's homepage as well as in our searchable, web-based "Buyer's Guide" to be launched in 2023.
- WCPA Website "Industry Link" (\$150.00 annual value)



For more information or to *apply online*, please visit www.wichiefs.org and select the "Supporting Business Member Details" option from the *Quick Links* menu or contact WCPA Executive Director Pete Peters via email ppeters@wichiefs.org or phone: 715-364-2367.

Membership becomes effective upon Executive Director's review/approval of membership application and payment of dues (\$500.00/year).

WWW.WICHIEFS.ORG





SUPPORTING BUSINESS MEMBERS





Membership Challenge

February 9th - August 1st, 2023

The success of any association relies heavily on its ability to retain as well as gain new members. Having a large membership base is particularly important to the WCPA as it plays a critical role in our ability to successfully advocate for legislation to advance our profession and vigorously oppose legislation that poses serious harm to Wisconsin law enforcement and the communities we serve.

The Membership Challenge is designed to help our Association grow by providing existing members with an additional incentive to introduce the WCPA to individuals in their professional and social networks they feel are viable candidates for membership.

From now until August 1st, existing members will earn an entry into a special drawing for a chance to win a Membership Challenge prize each time their name is listed as a "sponsor" on a new WCPA member's application form.

**OVER
\$5,750.00
IN PRIZES
AVAILABLE
TO WIN!**

Membership Challenge Prizes



(5) \$511.00 5.11 Tactical Gift Certificates
(\$2,555.00 total value)



(2) True Wireless Earbuds with Noise Canceling EAH-AZ60
(\$230.00 value ea.)



Glock 43XMOS Red Dot Pistol
(\$650.00 value)



Glock Pistol (Model TBD)
(\$400.00 value)



Kalahari Resort Getaway includes a 2-night Lodge Suite Stay
(\$500.00 Value)



(2) Staybridge Suites Wisconsin Dells-Lake Delton Getaway
(\$200.00 value ea.)



HYATT REGENCY GREEN BAY

2-night stay with \$75.00 food and beverage credit at Pub333 or The Market
(\$500.00 value)



AN IHG HOTEL

(2) Stays at Wisconsin Dells Holiday Inn Express
(\$150.00 value ea.)

Membership Challenge prize winners will be randomly drawn and announced on Monday, August 7th during Lunch at the 2023 WPLF Summer Training Conference in Green Bay.

NOTE: Winners do not need to attend the Conference to claim their prize.

For complete details and to apply online, visit www.wichiefs.org and click the "JOIN NOW" button.

For membership related information and support, please contact WCPA Executive Assistant Ray Appel via email rappel@wichiefs.org or by phone: 920-209-9472.



IS A PROUD PARTNER WITH



AVON
PROTECTION



We are the Winchester Law Enforcement distributor for the state of Wisconsin. Please contact us to find out Wisconsin state pricing.

JONATHANM@OHERRON.COM

➤ Please contact Jonathan Menges For further inquiry.



Jonathan Menges | (608)-282-5211 | jonathanm@oherron.com
3549 N. Vermilion St. Danville, IL 61832
WWW.OHERRON.COM | 1-800-223-2097

WISCONSIN SURPLUS ONLINE AUCTION

www.WisconsinSurplus.com

Recent Success Stories



2016 Tahoe LS 4wd Police

\$16,701.00



2017 Explorer AWD PPV

\$13,000.00



2004 F 550 Command Truck

\$20,501.00



Confiscated Item

We will sell your Confiscated, Seized
and Property Room items

\$415.00

Looking for an easy way to dispose of your Unused and Surplus items?

Try WisconsinSurplus.com. We will take your descriptions and pictures and sell your items in front of our 135,800+ registered bidders world-wide. We have been an online auction service for over 19+ years specializing in Municipal Equipment. Currently we sell items for Police Departments in Wisconsin, Illinois, Minnesota and the Upper Peninsula of Michigan. We also can sell your Property Room and Confiscated Items for you. We are Federal Firearms Licensed so if you are trading your duty weapons out or have some weapons you wish to sell we can handle that for you. Find out what these other Police Departments have already found out, that using Wisconsin Surplus is the easiest way to dispose of your unused and surplus items and make money doing it.

Give us a call 608-437-2001 or drop us an email at bid@wisconsinsurplus.com to find out how we can help you.



***Call us at 608-437-2001 to be
our next success story.***

BUMPER-TO-BUMPER VEHICLE SOLUTIONS

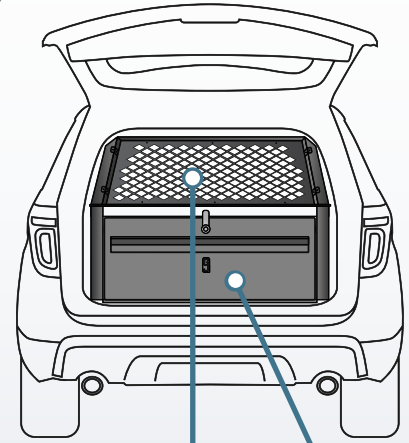
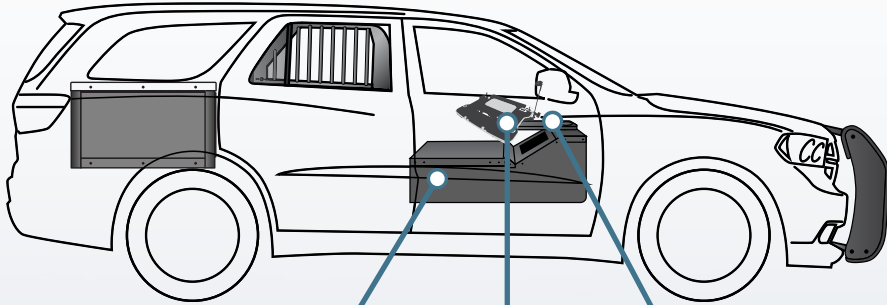

- PUSH BUMPERS**
- CONSOLE BOXES AND KITS**
- CRADLES & DOCKING STATIONS**
- MOTION ATTACHMENTS**
- WINDOW GUARDS**
- VEHICLE PARTITIONS**
- TRUNK BOX**



SCAN HERE TO VIEW THESE SOLUTIONS AND MORE:

	
CONSOLE BOXES & KITS	MOTION ATTACHMENTS
	
CRADLES & DOCKING STATIONS	POLICE & VEHICLE EQUIPMENT



@gamberjohnson #GamberJohnson
#RuggedReliableResponsive



RUGGED. RELIABLE. RESPONSIVE.

Looking for consoles, partitions, window guards, trunk storage, and other vehicle equipment for a new fleet build? Gamber-Johnson is your all-in-one manufacturer for a total BUMPER-TO-BUMPER vehicle solution. Gamber-Johnson will increase productivity while reducing replacement costs with in-vehicle mounting solutions to customize any mobile workspace, rugged device mounts, and motion attachments. Explore our complete vehicle solution at

WWW.GAMBERJOHNSON.COM

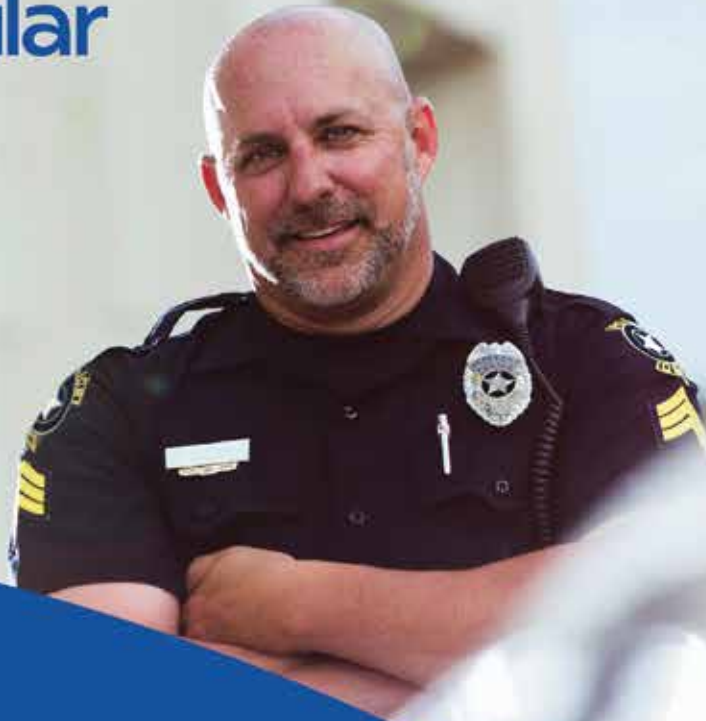

FOR EVERY EMERGENCY IN FRONT OF YOU, OUR LOCAL TEAM IS BEHIND YOU

*UScellular is proud
to sponsor and
support the
Wisconsin Chiefs of
Police Association*

*Critical Connectivity — First Responder Solutions
from UScellular® Business*

Count on UScellular® to deliver critical communications even when networks are crowded. With our locally grown Wisconsin network, we put towers where others don't to keep your emergency teams connected.

Contact your dedicated Wisconsin support manager to learn how UScellular can transform your operations.

Brynna Johnson
608-441-4415 | Brynna.Johnson@uscellular.com

Visit us at business.uscellular.com/solutions/public-safety



2023 WPLF SUMMER TRAINING CONFERENCE



SAVE THE DATE

2023 WPLF Summer Training Conference & Expo

August 6th – 9th



KI Convention Center | Green Bay, WI



TRUST ONE OF YOUR OWN



Jason E. Ganiere, CFP®
Financial Planning for Protective Services

- Retired law enforcement officer with 28 years of full-time service.
- Holds CERTIFIED FINANCIAL PLANNER™ designation.
- Advising law enforcement and fire fighters under a fiduciary standard of care since 2013.
- Backed by the team at IAG Wealth Partners, LLC, a Waukesha-based registered investment advisor.

To learn how decisions about your pension, deferred compensation, and other assets may impact your financial and retirement goals, schedule a complimentary review via Zoom using the QR code.



Investment advice offered through IAG Wealth Partners, LLC, a registered investment advisor.
N19W24200 Riverwood Dr., Ste 150 | Waukesha, WI 53188 | 262.446.8150 | www.iagwealthpartners.com



1952

2022

70 YEARS

WHELEN

PROUDLY SUPPORTING FIRST RESPONDERS IN WISCONSIN

**CELEBRATING
OVER 70 YEARS OF
MANUFACTURING
OUR PRODUCTS
IN AMERICA**

#WENEVERLEFT

**REACH OUT TO YOUR WISCONSIN REP FOR
MORE INFO OR TO SCHEDULE A DEMO!**

AUTHORIZED MANAGING SALES REPRESENTATIVE

W. REEVES & ASSOCIATES

NORWALK, IOWA 50211

(515) 981-5967

WREEVES.COM

BILL@WREEVES.COM

W|REEVES
and Associates

WHELEN[®]
ENGINEERING COMPANY INC.

whelen.com

f t i n y @WhelenENG

COME SEE US AT BOOTH #V515